



Householder Pre-Application Form for Planning

Application Number:

Hyndburn Borough Council, Planning,
Scaitcliffe House, Ormerod Street, Accrington, BB5 0PF
Tel: 01254 380155 E-mail: planning@hyndburnbc.gov.uk

Received:

FOR
OFFICE
USE
ONLY:

Receipt No:
Amount Paid:
Date Fee Paid:

Code:
Paid By:
Payment Type:

TOWN & COUNTRY PLANNING ACT 1990

Please complete and return this form so we can determine whether or not you need planning permission for the proposed extension, conservatory, garage, carport or other free standing structure. **You should attach a plan of the property and the proposal with this form and all measurements should be accurate and in METRIC.** Please fill in all relevant sections as we may be unable to respond if you fail to provide all the information requested.

You should note that the completion of this form is NOT a planning application and the Council will inform you whether or not you need to submit an application.

You are advised to keep a copy of this completed form and the reply you receive from the Council as they will be of assistance if you ever decide to sell the property.

To see more about how we record and store your information please see the [Council's privacy notice](#).

1. Applicant Details:

Title:	First Name:	Surname:
Address:		Tel:
Postcode:		Mobile:
		E-mail:

2. Address of Proposed Development:

Postcode:

3. Is the property: Detached Semi-Detached Terraced/Mews

4. What works are you proposing to do? (e.g. single storey / two-storey extension, conservatory, balcony, roof/dormer extension etc.)

5. Is the proposal going to be at the: Front Rear Side

6. Is there a road at the side of the proposed extension: Yes No

7. **How high will the extension/ outbuilding be (in metres measured from ground level)?**
To the highest point: _____
To the eaves (bottom of roof): _____

8. **How far will the extension project in metres from the wall of the original property?**

9. **Will the eaves height (bottom of the roof) of the extension exceed the height of the eaves on the existing property?** Yes No

10. **Please state what type of roof you are proposing (e.g. flat, single pitch, dual pitch):**

11. **Will any part of the extension be higher than the highest part of the roof of the existing property?** Yes No

12. **Will any part of the extension/outbuilding come within 2 metres of the boundary of your property?** Yes No

13. **Will any part of the extension be higher than the highest part of the roof of the existing property?** Yes No (*Please mark distance on drawing*)

14. **Is your property within a conservation area or a Listed Building?** Yes No

15. **Have there been any previous extensions/outbuildings added to your house since it was originally built?** (This includes any conservatories, garages, sheds or greenhouse, including detached structures)
Yes No If you answer yes to this question, please provide a brief description including external measurements in metric: _____

16. **Is a new or altered vehicular or pedestrian access to the highway (road or pavement) proposed as part of the scheme?** Yes No (*If yes please mark on plan*)

17. **What are the materials of the existing property (e.g. brick, stone, render)?**

What materials will be used on the proposed extension?

18. **Pre-App Fee Inc. VAT at 20%:**
TOTAL: £

Follow up Meeting / Further Written Advice Inc. VAT at 20% (if applicable):
TOTAL: £

Total Payable Inc. VAT at 20% (Including Pre-App Fee & Follow up Meeting / Further Written Advice):
GRAND TOTAL: £

Fees are payable by cash, cheque or card.
Please make cheques payable to Hyndburn Borough Council.
Please ring 01254 380155 to pay by card.

19. Print Name:

Signed:

Date:

Sketch

Please provide a sketch plan of your proposal. This should include ALL the information requested along with measurements in metres. Any photographs or brochure extracts (e.g. conservatory plans, garage plans) you have will also assist the Planning Officer.

Please ensure you include:

1. Sketch of property and boundaries, indicating which is the front and rear of the property
2. How far the extension will project
3. How far the proposal will be from boundaries of the property
4. Any parts of the property to be demolished show dotted
5. Any new or altered vehicular and/or pedestrian access
6. Any existing extensions
7. Any existing outbuildings
8. A sketch of the extension showing the height to the top, to the eaves, length and width

Here is an example of a suitable sketch:

A. Site Plan

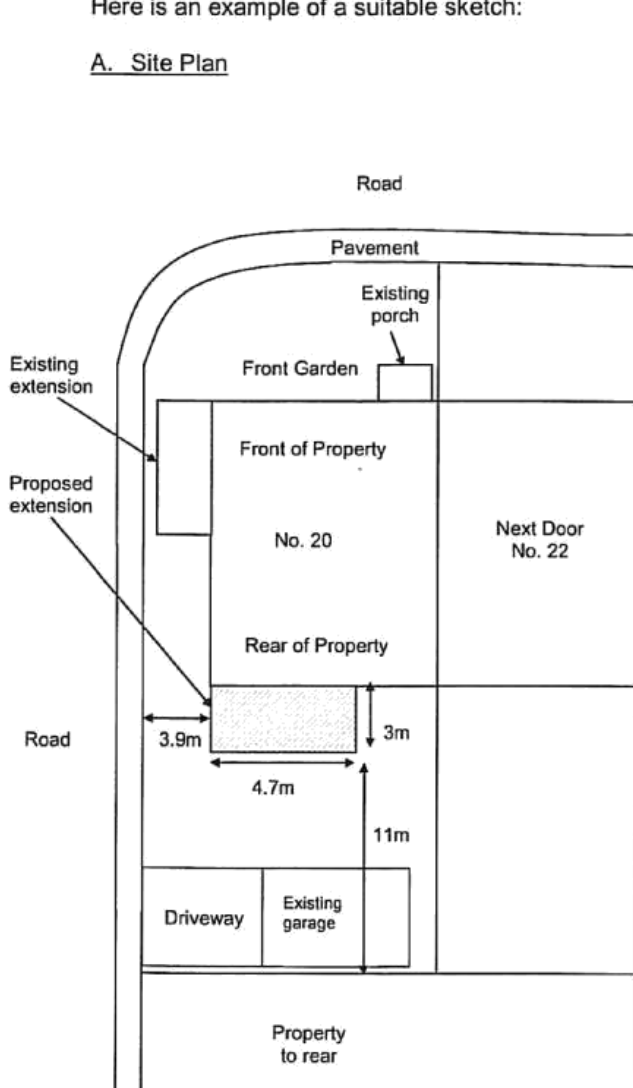

B. Sketch of extension

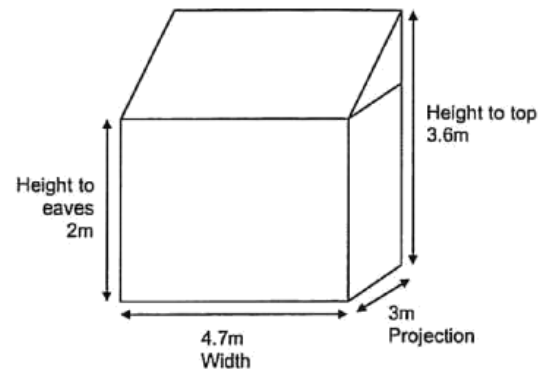

Please use the space overleaf or attach another sheet to provide your two sketches A and B.

Please note:

- We cannot proceed with your request for pre-application advice until we have received payment.
- Pre-application advice is subject to VAT.

Disclaimer regarding confidentiality:

Although the Council does not routinely publish the details of pre-application discussions, we can be required to disclose this information pursuant to the Freedom of Information Act 2000 or the Environmental Information Regulations 2004, unless a statutory exemption is applicable.

Exemptions can be applied for information which is legally confidential or commercially sensitive. If you believe that information may fall into one of these categories during pre-application discussions, you must notify the Council in writing and explain why you object to its disclosure and for how long this objection will last.

Even if you lodge an objection to the disclosure of information the final decision as to whether an exemption can be applied lies with the Council.